

# Monnit Commercial

## Wireless Light Detection Sensor (AA)



### Technical Overview

#### General Description

The Wireless Light Detection Sensor detects the presence of light.

#### Features

- Detects presence of light.
- Free iMonnit basic online wireless sensor monitoring and notification system to configure sensors, view data and set alerts via SMS text and email.

#### Principle of Operation

The Wireless Light Detection Sensor uses a photo resistor to detect the presence of light around the device. The sensor returns a value of light or no-light to the iMonnit Online Sensor Monitoring and Notification System. The data is stored in the online system and can be reviewed and exported as a data sheet or graph. Notifications can be set up through the online system to alert the user when light is present or not with the ability to only notify within time of day parameters.

#### Power Options

The standard version of this sensor is powered by two replaceable 1.5 V AA sized batteries (included with purchase).

This sensor is also available with a line power option. The line powered version of this sensor has a barrel power connector allowing it to be powered by a standard 3.0 - 3.6 V power supply. The line powered version also uses two standard 1.5 V AA batteries as backup for un-interrupted operation in the event of line power outage.

Power options must be selected at time of purchase, as the internal hardware of the sensor must be changed to support the selected power requirements.

#### Monnit Sensor Core Specifications

- Power: Two replaceable 1.5 V AA batteries (Option for line power with battery backup)
- Communication: RF 900, 920, 868 and 433 MHz
- Dimensions: 4.375" x 2.470" x 1.111"
- Antenna: 4" wire antenna
- Operating Temperature: -40° to 85°C (-40° to 185°F)  
Device Range: 250 - 300 ft. non-line-of-sight\*
- Battery Life: At 1 hour heartbeat setting, standard AA batteries will last up to 4 years.\*\*

\* Actual range may vary depending on environment.

\*\* Battery life is determined by sensor reporting frequency and other variables. Other power options are also available.

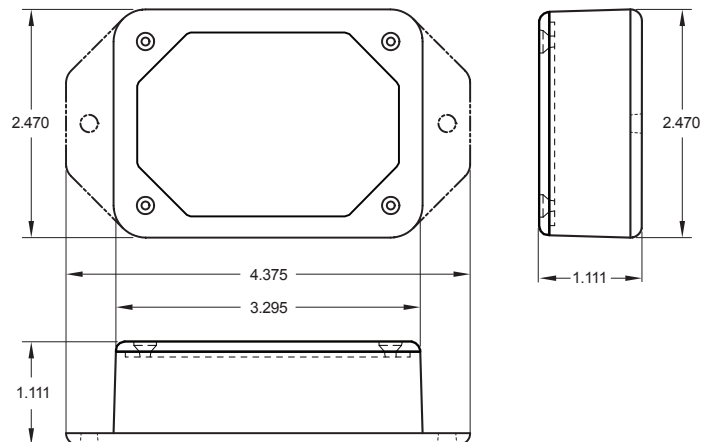

#### Example Applications

- Facilities management.
- Commercial property management.
- Home light monitoring.
- Small business light monitoring.

**The Leader in Low Cost Wireless Sensors**

| Technical Specifications                                    |  |
|---|--|
| Supply Voltage  | 2.0 - 3.6 VDC (3.0 - 3.6 VDC Using Power Supply) *   |
| Current Consumption   | 0.7 $\mu$ A (sleep mode)<br>2 mA (radio idle/off mode)<br>2 mA (measurement mode)<br>25 mA (radio RX mode)<br>35 mA (radio TX mode)  |
| Operating Temperature Range (Board Circuitry and Batteries) | -18°C to 55°C (0°F to 130°F) using alkaline<br>-40°C to 85°C (-40°F to 185°F) using lithium **   |
| Optimal Battery Temperature Range (AA)                      | +10°C to +50°C ( +50°F to +122°F )   |
| Angle of Half Sensitivity                                   | $\phi = \pm 50^\circ$  |
| Max Light Level   | 0 - 1,000 Lux  |
| Certifications  | <br>900 MHz product; FCC ID: ZTL- RFSC1 and IC: 9794A-RFSC1. 920 MHz product; ARIB STD-T108 R210-103733. 868 and 433 MHz product tested and found to comply with: CISPR 22:2008-09 / EN 55022:2010 - Class B and ETSI EN 300 220-2 V2.4.1 (2012-05). |

\* Hardware cannot withstand negative voltage. Please take care when connecting a power device.

\*\* At temperatures above 100°C, it is possible for the board circuitry to lose programmed memory.

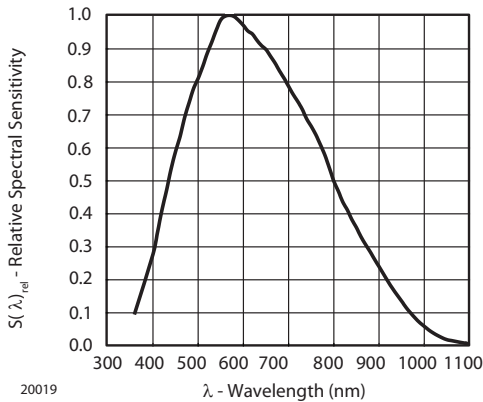

Fig. 1 - Relative Spectral Sensitivity vs. Wavelength

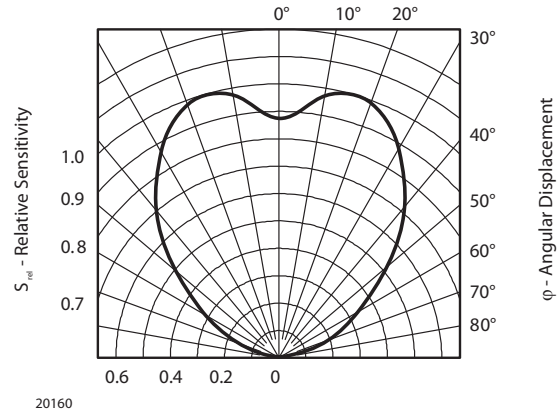

Fig. 2 - Relative Radiant Sensitivity vs. Angular Displacement

### Caution/Notice:

This product is designed for application in an ordinary environment (normal room temperature, humidity and atmospheric pressure). Do not use this sensor under the following conditions as these factors can deteriorate the product characteristics and cause failures and burn-out.; corrosive gas or deoxidizing gas - chlorine gas, hydrogen sulfide gas, ammonia gas, sulfuric acid gas, nitric oxides gas, etc.), volatile or flammable gas, dusty conditions, under low or high pressure, wet or excessively humid locations, places with salt water, oils chemical liquids or organic solvents, where there are excessively strong vibrations, other places where similar hazardous conditions exist.

Use this product within the specified temperature range. Higher temperature may cause deterioration of the characteristics or the material quality of this product.

For more information about our products or to place an order, please contact our sales department at 801-561-5555.

Visit us on the web at [www.monnit.com](http://www.monnit.com).



Monnit Corporation  
4403 South 500 West  
Murray, UT 84123  
801-561-5555  
[www.monnit.com](http://www.monnit.com)