

Monnit

Wireless Vehicle Sensors



Technical Overview

General Description

The Wireless vehicle sensors can be used in a host of applications where detecting or counting vehicles is needed. Two different vehicle sensors are available.

Features

- Detects presence of vehicles up to 8 feet away.
- Can detect and count stationary or moving vehicles.
- Free iMonnit basic online wireless sensor monitoring and notification system to configure sensors, view data and set alerts via SMS text and email.

Principles of Operation

Vehicle Detection - Detects the presence or absence of a parked or stationary vehicle.

Vehicle Counter - Detects and counts vehicles in motion as they pass by.

Power Options

Sensors are powered by a replaceable 3.0 V coin cell battery. Optional AA battery powered sensors are available. The AA version of these sensors are larger in size (3" [L] x 2.1" [W] x 1.2" [H]) and include two long-life AA batteries.

It is recommended that unless you are using the AA battery solution, you set heartbeat to no faster than one hour to preserve battery life.

Monnit Sensor Core Specifications

- Power: Replaceable 3.0 V coin cell battery
- Communication: RF 900, 920, 868 and 433 MHz
- Dimensions: 1.775" x 1.040" x 0.785"
- Antenna: 4" wire antenna
- Operating Temperature: -7° to 60°C (20° to 140°F)
- Device Range: 250 - 300 ft. non-line-of-sight*
- Battery Life: At 1 hour heartbeat setting, coin cell battery will last ~ 1-2 years.**

* Actual range may vary depending on environment.

** Battery life is determined by sensor reporting frequency and other variables.

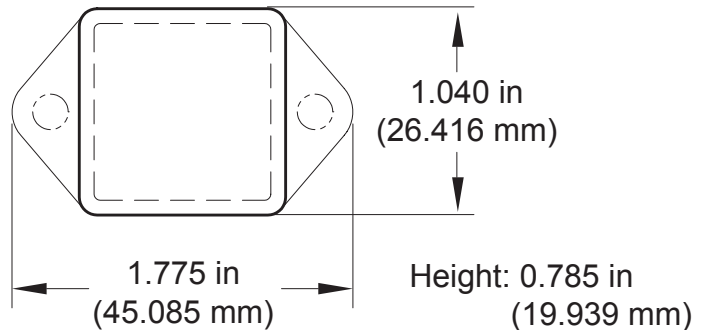

Example Applications

- Parking Garages
- Traffic Monitoring
- Automotive Services
- Fleet Management
- And many more...

The Leader in Low Cost Wireless Sensors

Technical Specifications	
Vehicle Sensing Distance	Up to 8 feet
Field Range (Full scale (FS) - total applied field)	-8 to +8 gauss
Mag Dynamic Range (3-bit gain control)	±1 to ±8
Resolution (VDD=3.0V, GN=2)	5 milli-gauss typ.
Linearity (±2.0 gauss input range)	0.1 ±% FS max
Hysteresis (±2.0 gauss input range)	±25 ppm typ.
Cross-Axis Sensitivity (Cross field = 0.5 gauss)	±0.2% FS / gauss
Output Rate (Continuous Measurement Mode)	0.75 to 75 Hz
Output Rate (Single Measurement Mode)	160 Hz max
Measurement Period	6 msec typ.
Gain Tolerance	±5%
Gain Tolerance (Ambient, unbiased)	-40 to +125°C
Operating Temperature Range (Board Circuitry and Coin Cell)	-7°C to +60°C (20°F to +140°F)*
Optimal Battery Temperature Range (Coin Cell)	+10°C to +50°C (+50°F to +122°F)
Certifications	 900 MHz product; FCC ID: ZTL- RFSC1 and IC: 9794A-RFSC1. 920 MHz product; ARIB STD-T108 R210-103733. 868 and 433 MHz product tested and found to comply with: CISPR 22:2008-09 / EN 55022:2010 - Class B and ETSI EN 300 220-2 V2.4.1 (2012-05).

* At temperatures above 100°C, it is possible for the board circuitry to lose programmed memory.

Caution/Notice:

This product is designed for application in an ordinary environment (normal room temperature, humidity and atmospheric pressure). Do not use this sensor under the following conditions as these factors can deteriorate the product characteristics and cause failures and burn-out.

- Corrosive gas or deoxidizing gas - chlorine gas, hydrogen sulfide gas, ammonia gas, sulfuric acid gas, nitric oxides gas, etc.).
- Volatile or flammable gas.
- Dusty conditions.
- Under low or high pressure.
- Wet or excessively humid locations.
- Places with salt water, oils chemical liquids or organic solvents.
- Where there are excessively strong vibrations.
- Other places where similar hazardous conditions exist.

Use this product within the specified temperature range. Higher temperature may cause deterioration of the characteristics or the material quality of this product.



For more information about our products or to place an order, please contact our sales department at 801-561-5555.

Visit us on the web at www.monnit.com.

Monnit Corporation
 4403 South 500 West
 Murray, UT 84123
 801-561-5555
www.monnit.com