



## Wireless High Temperature Sensor

### General Description

The RF Wireless High Temperature Sensor uses a glass coated platinum RTD sensor to accurately measure temperatures from -50°C to +370°C (-58°F to 700°F).

- Standard accuracy at 0°C: +/- 3.3°C
- Calibrated accuracy at 0°C: +/- 0.5°C
- RTD temperature range: -50°C to +370°C (-58°F to 700°F)



Free iMonnit basic online wireless sensor monitoring and notification system to configure sensors, view data and set alerts via SMS text and email.

### Principle of Operation

The Monnit Wireless High Temperature Sensor outputs the ambient temperature in degrees Celsius or Fahrenheit. It is programmed to sleep for a user-given time interval (heartbeat) and then wakeup, power up the RTD sensor and wait for it to stabilize then mathematically compute the temperature and transmit the data to the gateway.

Industry leading 25 month NIST certified product included on leaded temperature sensors.



The High Temperature Sensor is not meant for wet, damp, high humidity environments. This sensor should only be operated in dry, low humidity environments. Should you need a temperature sensor that operates at extreme temperatures and can withstand getting wet or condensed on, please consider our Thermocouple Sensors.

### Example Applications

- Heaters & Boilers
- Ovens & Cooking Devices
- Environmental Monitoring
- Smart Machines & Smart Structures
- HVAC Operation & Testing

### Monnit Sensor Core Specifications

- Wireless Range: 250 - 300 ft. (non-line-of-sight / indoors / through walls, ceilings & floors) \*
- RF Communication: 900, 920, 868 and 433 MHz
- Power: Replaceable batteries (optimized for long battery life, line-power and solar (Industrial only) options are available)
- Battery Life (at 1 hour heartbeat setting): \*\*
  - AA battery > 4-8 years
  - Industrial > 4-8 years
  - Wifi > Up to 5 years

\* Actual range may vary depending on environment. (Wi-Fi sensor typical range up to 100 ft.)

\*\* Battery life is determined by sensor reporting frequency and other variables.

### Sensor Types & Options

Wireless High Temperature Sensor (AA)	2
Wireless High Temperature Sensor (Industrial)	3
Wireless High Temperature Sensor (MOWI Wi-Fi)	5
Notes	6

# Wireless High Temperature Sensor (AA)

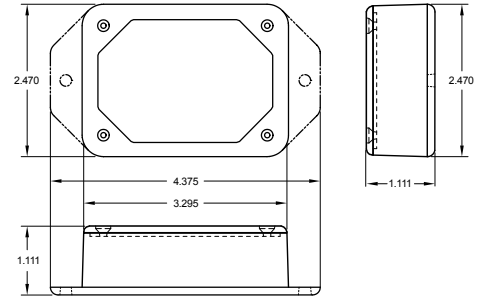

Technical Specifications	
Supply Voltage	2.0 - 3.6 VDC (3.0 - 3.6 VDC Using Power Supply) *
Current Consumption	0.7 $\mu$ A (sleep mode)
Operating Temperature Range (Board Circuitry and Batteries)	-18°C to 55°C (0°F to 130°F) using alkaline -40°C to 85°C (-40°F to 185°F) using lithium **
Weight	3.7 oz. (3.7 oz w/ 3' probe)
Wireless Range	250 - 300 ft. (Indoors / Through walls, ceilings & floors) Range may vary according to environmental variables

\* Hardware cannot withstand negative voltage. Please take care when connecting a power device.

\*\* At temperatures above 100°C, it is possible for the board circuitry to lose programmed memory.

RTD Technical Specifications	
RTD Temperature Range (RTD and Cable Only)	-50°C to +370°C (-58°F to +700°F)
Accuracy @ 0°C	+/- 3.3°C Standard (+/- 0.5°C Calibrated **)
Dissipation Constant	2mW/°C
Thermal Time Constant	15 sec max.

RTD Tolerances		
Temperature (°C)	Tolerance ( $\pm$ °C)	
	Uncalibrated	Calibrated
- 50°C	3.55	0.75
- 30°C	3.45	0.65
- 10°C	3.35	0.55
0°C	3.30	0.50
10°C	3.35	0.55
30°C	3.45	0.65
50°C	3.55	0.75
70°C	3.65	0.85
90°C	3.75	0.95
110°C	3.85	1.05
130°C	3.95	1.15
150°C	4.05	1.25
170°C	4.15	1.35
190°C	4.25	1.45
210°C	4.35	1.55
230°C	4.45	1.65
250°C	4.55	1.75
270°C	4.65	1.85
290°C	4.75	1.95
310°C	4.85	2.05
330°C	4.95	2.15
350°C	5.05	2.25
370°C	5.15	2.35

## Certifications



900 MHz product; FCC ID: ZTL- RFSC1 and IC: 9794A-RF-SC1. 920 MHz product; ARIB STD-T108 R210-103733. 868 and 433 MHz product tested and found to comply with: CISPR 22:2008-09 / EN 55022:2010 - Class B and ETSI EN 300 220-2 V2.4.1 (2012-05).

## Power Options

Two replaceable 1.5V AA sized batteries are included with the standard model. A line-power version with battery backup is also available - allowing it to be powered by a standard 3.0 - 3.6V power supply and use the internal batteries if there is a power interruption.

Power options must be selected at time of purchase as the internal hardware of the sensor must be changed to support the selected power requirements.

## Wireless High Temperature Sensor (Industrial)

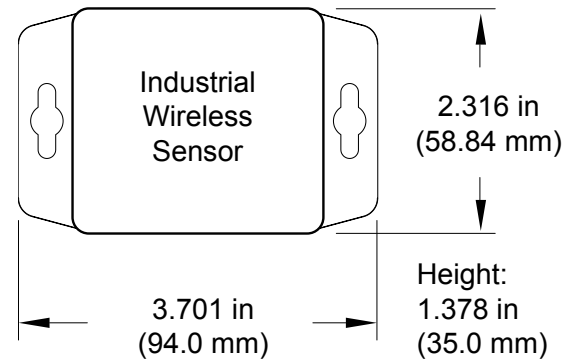

### Technical Specifications

Supply Voltage	2.0 - 3.6 VDC *	
Current Consumption	0.7 $\mu$ A (sleep mode) 2 mA (radio idle/off mode) 2 mA (measurement mode) 25 mA (radio RX mode) 35 mA (radio TX mode)	
Operating Temperature Range (Board Circuitry and Battery)		
Included Battery	Max Temperature Range:	-40°C to +85°C ( -40°F to +185°F ) **
	Capacity:	1500 mAh
Optional Solar Feature	Solar Panel:	5VDC / 30mA (53mm x 30mm)
	Charging Temperature Range:	0° to 45°C (32° to 113°F)
	Max Temperature Range:	-20° to 60°C (-4° to 140°F)
	Included Rechargeable Battery:	600 mAh / >2000 Charge Cycles (80% of initial capacity)
	Charging efficiency	5% ***
	Luminous sustainability	Minimum of 10,000 LUX ***
Enclosure Rating	NEMA 1, 2, 4, 4x, 12 and 13 rated, sealed and weather proof	
UL Rating	UL Listed to UL508-4x specifications (File E194432)	
Lead Wire Length	3' (36 in.)	
Weight	4.8 oz (solar option 5.2 oz.)	
Wireless Range	250 - 300 ft. (Indoors / Through walls, ceilings & floors) Range may vary according to environmental variables.	
Certifications	 900 MHz product; FCC ID: ZTL- RFSC1 and IC: 9794A-RFSC1. 920 MHz product; ARIB STD-T108 R210-103733. 868 and 433 MHz product tested and found to comply with: CISPR 22:2008-09 / EN 55022:2010 - Class B and ETSI EN 300 220-2 V2.4.1 (2012-05).	

\* Hardware cannot withstand negative voltage. Please take care when connecting a power device.

\*\* At temperatures above 100°C, it is possible for the board circuitry to lose programmed memory.

\*\*\* Solar Feature is only chargeable outside on full sunlight.

### RTD Technical Specifications

RTD Temperature Range (RTD and Cable Only)	-50°C to +370°C (-58°F to 700°F)
Accuracy @ 25°C	+/- 0.5°C (0.9°F)
Dissipation Constant	2mW/°C
Thermal Time Constant	15 sec max.

\*\*\* For best results, calibrate at 0°C..

## Wireless High Temperature Sensor (Industrial continued)



### Solar Power Option

Monnit Industrial Sensors are powered by a replaceable 3.6V Lithium battery (included). An optional solar powered version is also available. The solar powered sensor uses a Lithium Iron Phosphate rechargeable battery in conjunction with a solar power cell to extend battery life.

RTD Tolerances		
Temperature (°C)	Tolerance (±°C)	
	Uncalibrated	Calibrated
- 50°C	3.55	0.75
- 30°C	3.45	0.65
- 10°C	3.35	0.55
0°C	3.30	0.50
10°C	3.35	0.55
30°C	3.45	0.65
50°C	3.55	0.75
70°C	3.65	0.85
90°C	3.75	0.95
110°C	3.85	1.05
130°C	3.95	1.15
150°C	4.05	1.25
170°C	4.15	1.35
190°C	4.25	1.45
210°C	4.35	1.55
230°C	4.45	1.65
250°C	4.55	1.75
270°C	4.65	1.85
290°C	4.75	1.95
310°C	4.85	2.05
330°C	4.95	2.15
350°C	5.05	2.25
370°C	5.15	2.35

## Wireless High Temperature Sensor (MOWI Wi-Fi)

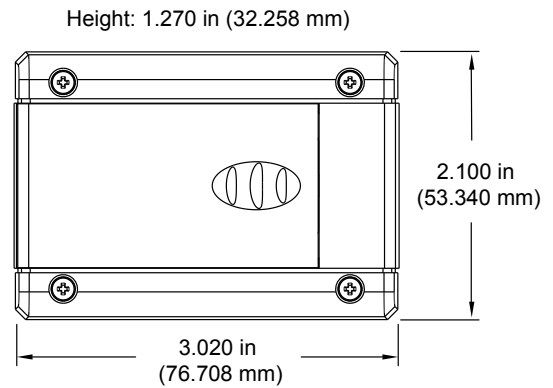

### Technical Specifications

Networking Standards	IEEE 802.11 b/g
Frequency Band	2.412 - 2.484 GHz
Wi-Fi Security Standards	Open, WEP, WPA, WPA2
Wi-Fi Security Programming	Via PC software using USB cable. (Can be changed through iMonnit online software.)
Network Settings	Auto DHCP/DNS or Static
Data Logging	Standard - On Wi-Fi disruption, unit will log the first 50 readings and transmit when Wi-Fi connection is re-established. Premiere - Unit can record up to 50,000 readings and transmit when Wi-Fi is available.
Power consumption	4uA sleep, 35mA active RX, 180mA TX (at +12dBm)
Battery Life	Up to 5 years depending on sensor type, Wi-Fi security, distance from Wi-Fi router, reporting frequency and other variables. (Testing surpassed 90,000 transmissions until battery depletion.)
Wi-Fi Data Rate	Auto configures to best rate for maximum range.
Electronics Operating Temperature	Using Alkaline Batteries: -18°C to +55°C (0°F to +130°F) Using Lithium Batteries: -40°C to +85°C (-40°F to +185°F)
LED Light	Status / activity
Weight	3.8 oz.
Wireless Range	Up to 100 ft. device range (typical to standard Wi-Fi devices) Range may vary according to environmental variables.
Certifications	 FCC ID: T9J-RN171. IC: RSS-210 low-power communication device. CE ID: 0681.

\* Hardware cannot withstand negative voltage. Please take care when connecting a power device.

\*\* At temperatures above 100°C, it is possible for the board circuitry to lose programmed memory.

### RTD Technical Specifications

RTD Temperature Range (RTD and Cable Only)	-50°C to +370°C (-58°F to 700°F)
Accuracy @ 25°C	+/- 0.5°C (0.9°F)
Dissipation Constant	2mW/°C
Thermal Time Constant	15 sec max.



### High Gain Antenna Option

Monnit Wi-Fi sensors are also available with a detachable high gain antenna to provide a 20-30% increase in range over the standard Wi-Fi sensor. Option uses a different hardware configuration and must be chosen at time of purchase.

## Notes

### Commercial Grade Sensors

Monnit commercial grade sensors are designed for applications in ordinary environments (normal room temperature, humidity and atmospheric pressure). Do not use these sensors under the following conditions as these factors can deteriorate the product characteristics and cause failures and burn-out.

- Corrosive gas or deoxidizing gas - chlorine gas, hydrogen sulfide gas, ammonia gas, sulfuric acid gas, nitric oxides gas, etc.).
- Volatile or flammable gas.
- Dusty conditions.
- Under low or high pressure.
- Wet or excessively humid locations.
- Places with salt water, oils chemical liquids or organic solvents.
- Where there are excessively strong vibrations.
- Other places where similar hazardous conditions exist.

Use these products within the specified temperature range. Higher temperature may cause deterioration of the characteristics or the material quality.

### Industrial Grade Sensors - Type 1, 2, 4, 4X, 12 and 13 NEMA Rated Enclosure

Monnit's Industrial sensors are enclosed in reliable, weatherproof NEMA rated enclosures. Our NEMA rated enclosures are constructed for both indoor or outdoor use and protect the sensor circuitry against the ingress of solid foreign objects like dust as well as the damaging effects of water (rain, sleet, snow, splashing water, and hose directed water).

- Safe from falling dirt.
- Protects against wind-blown dust.
- Protects against rain, sleet, snow, splashing water, and hose directed water
- Increased level of corrosion resistance
- Will remain undamaged by ice formation on the enclosure



For more information about our products or to place an order, please contact our sales department at 801-561-5555.

Visit us on the web at [www.monnit.com](http://www.monnit.com).

Monnit Corporation  
3400 South West Temple  
Salt Lake City, UT 84115  
801-561-5555  
[www.monnit.com](http://www.monnit.com)